

KNOWLEDGE MANAGEMENT IN PRODUCT DEVELOPMENT PROCESS: PROPOSAL AND APPLICATION

Cristiano Vasconcellos Ferreira¹, Maria Teresinha Tamanini Andrade² and Karina Barreto Villela³

¹SENAI BA Cimatec, Brazil

²CEFET BA, Brazil, and ³UNIFACS, Brazil

ABSTRACT

Knowledge is considered the most important asset in companies. It has a significant impact in the competitiveness of the companies. The Knowledge Management (KM) is fundamentally important in the product development process (PDP) as a meaning to share information among the team who are involved in the product life cycle. PDP is a process, which companies transform client's information, market and technical opportunities into products and/or services that are disposed to the market. The objective of this paper is to describe a methodology to introduce the KM in the product development process in a Research Center that supplies services in this area. In this sense, this paper presents the concept of the KM, the modelling process and the product development process. In the sequence, it presents a methodology to introduce the KM in companies and its application at SENAI Cimatec – Integrated Manufacturing and Technology Centre. And, finally, the conclusions will be described.

Keywords: Knowledge Management, Product Development Process, Ontology

1 INTRODUCTION

To insure the sustainability of the competitive advantage provided through knowledge, the human and company knowledge should not be remained in the individual level. Knowledge in companies is lose when individuals leave the company, project are finished and information are not registered in a correctly way. Organizational knowledge recorded in documents also represents a problem when it cannot be easily accessed, shared and updated.

Clark and Fujimoto [1] defined Product Development Process (PDP) as a process, which companies transform client's information and market and technical opportunities in products and/or services. During the PDP, the team must share information, as client's needs, product's requirement and specification, technical and economical reports and others. Considering that products are increasing in complexity, and companies need to reduce time to launch products in the market, the development of the KM strategies is a challenge for the companies. In this scenario, companies must integrate the design team and introduce practices to manage its knowledge.

The objective of this paper is to describe a methodology to model and introduce the KM in companies that develop products and also to demonstrate the experience, which was developed at SENAI Cimatec - Integrated Manufacturing and Technology Centre. SENAI Cimatec is an integrated technology and education centre that is dedicated to improve the industry competitiveness; it contributes to the modernization of the local manufacturing industry, and it's focused in the small and mid size companies.

Initially are described the concept of KM, process modelling and product development process. In the sequence, it is presented a methodology to introduce the KM in companies and its application at the SENAI Cimatec. And, finally, the conclusions of this paper are going to be described.

2 KNOWLEDGE MANAGEMENT

Knowledge is considered the most important asset to the company, having a significant impact on its competitiveness [2]. However, to secure the sustainability of the competitive advantage provided

through knowledge, it should not remain in the individual level, it must be shared by the all organization.

Drucker [3] has pointed out that traditional production factors such as labor work, capital and natural resources have become less important when comparing to company's knowledge in this new era. Stewart [4] reinforce that the idea suggests that in this new "era of information" the fundamental sources of wealth are knowledge and communication, and not natural resources or labor work [5].

Davenport and Prusak [6] differentiate these three classes of elements: i) Data is a discreet and facts objective group of a certain event; ii) Information is a message that contains an originator and a receiver, and the meaning involves a new interpretation based on a group of data, and; iii) Knowledge is a mixture of experiences, values, contextual information and intuition, forming a framework in a person's mind that enables him/her to evaluate and to obtain new experiences and information.

Nonaka and Takeuchi [7] identified two types of knowledge. Tacit knowledge is the knowledge that people possess but it is not described in any place. It is just residing in their heads. Explicit knowledge is registered in some ways and therefore it is available for other people. Considering this distinction, people, process models and artifacts, including documents, communications, prototypes, and final products can be organized, registered and analysed to be transformed in knowledge and support the business strategy.

Nonaka and Takeuchi [7] have also suggested four basic conversion patterns for the knowledge creation in an organization: from tacit knowledge to tacit knowledge or socialization; from tacit knowledge to explicit knowledge or externalization; from explicit knowledge to explicit knowledge or combination; and, from explicit knowledge to tacit knowledge or internalization.

Knowledge Management (KM) can be defined as a systematic and active management of corporate knowledge resources, using appropriate technology and aiming at generating strategic benefits to the organization, which involve: i) obtaining relevant knowledge from internal and/or external sources; ii) disseminating the obtained knowledge in a way, which is appropriated for the user's needs; iii) promoting the creation of new knowledge, and; iv) eliminating outdated knowledge.

However, the knowledge management strategy will depend on the company strategic goals [2,8]. To implement KM, technical and non-technical aspects should be considered. Technical aspects are related to the procedures and software tools to manage routines, services, information and others information. Non technical aspects are related to the company memory and culture.

According Skyrme [9], successful implementation of Knowledge Management depends on giving the appropriate focus to non-technical aspects such as human factors, social factors and culture.

In these scenarios, integration between Knowledge Management and Business Process Modeling has become increasingly popular since 2001 [10], causing the increase of the use of the Process-Oriented Knowledge Management term. This approach consists in using business processes as a dimension for organizing companies' knowledge and it is considered process-oriented because others dimensions are also needed to deal with knowledge that cannot be directly associated to business processes [11]. According to Maier and Remus [12], the objective of the approach is to provide the knowledge, which is a requirement for the company employees to carry out the tasks throughout the execution of the business processes. In the sequence are listed some reasons to implement a Process-Oriented Knowledge Management in companies:

- process models hold knowledge about the company processes;
- companies need to understand their processes as a whole in order to be able to improve them and make them available to employees for guidance [13];
- individuals need to understand their role within a company process [13];
- people need knowledge to carry out activities; not for their own sake [14];
- processes are natural entities for managers and for project teams in many domains, which means they are used to think of processes [14];
- processes provide important context to facilitate both the dissemination of knowledge according to the user's objectives, and its understanding [12].

Information must be organized to be accessed when the design team need. To support the information access it must be structured and classified. Taxonomy, ontology and process models are fundamentally important to support the information classification [15]. Taxonomy defines object classes and object subclasses. Ontology is a formal and explicit specification of a concept that must be shared [16]. Reference [16] stresses the taxonomy importance to facilitate and increase the information (structured knowledge) process research and, it stresses that the correct definition of all company process is

fundamental to define an efficient taxonomy. Other approach is to use the ontology to classify the organizational knowledge, to support the semantic research knowledge, to dispose to the design team and other users and to facilitate the communication among multiple users and the association among multiples knowledge bases. Ontology must able users to establish the knowledge resource that they need [10]. The objective to construct ontology is to dispose a language, which is related to the interested domain.

3 PROCESS MODELING METHODOLOGY

According to Cruz [16], process is a whole of activities to support the human resource in the business development. Process can be shared in sub-process, activities, procedures and tasks. Models are abstractions that portray the essential of a complex problem or structure by filtering out non-essential details [14], thus making the problem or structure easier to understand, analyze and verify. Therefore, models can hold relevant information about processes or any observable action while dealing with complexity through hiding the unnecessary details.

A process is a set of structured activities whose objective is to produce an artifact or service of value for the organization itself, its clients or its business market. Process models usually describe (or prescribe) the process activities and their inter-relationships, clearly identifying starting and ending points, inputs and outputs as well as the necessary resources.

- Process models are descriptive when they aim to promote an understanding of the processes and facilitate communication, allowing a shared view of these processes.
- Process models are prescriptive when they provide instructions showing how the processes should be carried to reach the intending objectives.

There is a number of criteria, which the merit of product proposing models of development process should be judged. If a model has useful predictive value, it must meet several criteria: it addresses an important managerial issue; the decision making is based on the information that is available and accurate; the assumptions and simplifications of the model are reasonable; and the model is computationally tractable [17]

Many languages and formalisms have been proposing throughout process modeling. However, the complexity of existing languages, given their strong orientation towards supporting process execution and automation, has rendered difficult their use in practice. The most important aspect in the practice is to communicate and to promote an understanding of the processes. Therefore, process modelling languages must be easy to use, intuitive and tolerant, so process models can be created incrementally.

Vilella [11] proposed a language for modeling process, which there is a descriptive purpose and differs from the previous ones in that: (i) it defines a minimum set of element types, including objects and associations, which are considered important to represent the applicable concepts of an Enterprise Ontology; (ii) it can represent the required and produced knowledge throughout processes and (iii) it makes use of notations using simple shapes. The resulting language is intuitive, easy to use and able to produce models that are easy to read, pleasant to visualize and appropriate for representing the flow of knowledge. This language is used in this paper.

4 PRODUCT DEVELOPMENT PROCESS

Product development process (PDP) is a critical function of technology-based firms. The success of product development efforts can determine the long term viability of companies and economies. PDP is an activity that people, who are involved in product life cycle, develop actions that affects almost all areas of human life, use the law and insights of science, build upon special experience and provide the prerequisites for the physical realisation of solution activities.

Product development is the process, which clients' needs are converted into technical (quality, cost, time and development) and commercial solutions (product and service). Each product development process is unique, yet the processes share common features or elements. If we can understand what those processes have in common we may be able to guide the management of future product development processes.

Basically, the PDP can be structured in three main phases: i) pre development; ii) product development; iii) post development. The company strategy for the product design, the product portfolio and product planning are defined in the pre development phase. The product development phase can be structured in the following steps: definition of the product' specification, conceptual design, embodiment design, detailed design and design of manufacturing process. In the post

development phase is measuring the technical and economical performance of the product in the market and its retirement, if needs.

On the most important phase is the definition of the product specification and conceptual design phase, because the product performance during its life cycle is defined.

In the specification of the development phase the goal is to develop a clear statement of the product requirements in terms of performance, time available, money to be spent, recycling, maintainability, and others. In this phase must be identified the clients, considering the product's life cycle, defining the clients' needs and product's requirement and restrictions.

In the conceptual design phase the main characteristics of the product is defined. Traditionally, the phase of the design process has been the least management, the least documented, and the least understood. For this reason, the knowledge management takes a great importance.

5 A PROPOSAL TO MODEL THE KNOWLEDGE MANAGEMENT IN COMPANIES

The solution in KM must be customized to the companies considering their culture, technology level and their strategies. A methodology to implement the KM in companies is described in the context of this section. [22]

Phase 1: To define KM Company objectives. It includes the following activities:

Step 1.1. To characterize company;

Step 1.2. To identify Information Technology (IT) structure, including hardware and software;

Step 1.3. To identify the company business process;

Step 1.4. To identify the type of knowledge that is presented in the company. The knowledge that can be documented or not;

Step 1.5. To define the KM objectives according to the company objectives, as well as, the metrics that will be used to measure the benefic of the KM implementation.

Phase 2: To define the knowledge structure to support the KM objectives of the companies, which were defined in Phase 1.

Step 2.1. To define structure components that will support the KM, i.e., the structure of the document, access, share and update the knowledge.

Step 2.2. To define the users of the KM structure based on the company culture;

Step 2.3. To develop used cases based on the company business process and the users activities;

Step 2.4. To define the KM team of the company as: knowledge manager, knowledge developer, users and others.

Phase 3: To develop the company knowledge. The objective is to arrange the company knowledge to the employees.

Step 3.1. To define how the company will extract and register the knowledge;

Step 3.2. To extract and register the knowledge;

Step 3.3. To define knowledge representation schemes and to classify the different knowledge types;

Phase 4: To develop the technical structure of the KM System that will be implemented in the company.

Step 4.1. To define the technical structure architecture. This definition will help identify the current application that will be integrated in the KM, as well as, the application that must be developed;.

Step 4.2. To develop architectural components to integrate application in used, as well as, one that will be developed.

Step 4.3. To revise the representation scheme and the knowledge classification that it will compose the KM Company System.

Phase 5: To implement the KM System.

Step 5.1. To fulfill the KM System bases with the knowledge registered in Phase 3.

Step 5.2. To establish the strategies to manage the system changes. To define and to implement strategies to share the knowledge and to register the new knowledge from new users.

Step 5.3. To establish procedures to keep the KM System

Step 5.4. To launch the KM System. It is possible to launch the system in parts.

Phase 6: To evaluate the KM performance and the investment.

Step 6.1. To evaluate the system, considering the user's needs and requirements.

Step 6.2. To measure the benefits of the KM System, considering the company objectives.

6 IMPLEMENTATION OF A KNOWLEDGE MANAGEMENT SYSTEM IN DETAILED DESIGN PROCESS AT SENAI CIMATEC-BA

SENAI BA Cimatec is an integrated manufacturing and technology centre, which is dedicated to improve the competitiveness of the industry, helping the modernization of the local manufacturing industry. In the product design field, SENAI Cimatec develops product for clients. The PDP model of SENAI Cimatec was proposed based on Ferreira [19] and it was the base to apply the described methodology in the section 4. This area was selected due to some challengers:

- The design team has difficulty to understand the PDP Methodology in terms of the information, responsibility, client's interaction, involved areas, communication among engineers;
- The construction of the knowledge during the PDP, involves both knowledge acquisition from external sources (documents, clients information, standards) and the capture of knowledge, which already exists in the company. The definition of the knowledge representation and index schemes can start at this point;
- Difficulty to increase the systematized knowledge during the PDP;
- Difficulty to identify professionals with desire competencies to develop the product;
- System evaluation and the measurement of its benefits, which means getting user's feedback about both the knowledge and the infrastructure that was provided and measuring the obtained benefits according to the Knowledge Management and business goals.

The methodology was applied to analyze the results that were already obtained from the previous efforts to manage knowledge in the company, setting the current situation. Then the type and the quantity of work to be done to attain the Knowledge Management goals, which were established by the company, were determined. This initial analysis revealed that the company had already acquired Knowledge Management product (WebDesk) that is capable to manage electronic documents and workflows, which offer support to corporative web sites and communities. They also used a general taxonomy to classify documents, making possible the identification of the scope of its use: all the industries in the state, all SENAI units or a specific unit. In addition, the desired effect of Knowledge Management within the company is the optimization, which is the efficient use of existing knowledge in the company to execute similar tasks and produce better solutions for these tasks. (Phase 1 and 2).

In Phase 3 was developed the diagnostic analyses to document the existed knowledge in PDP. It was developed the PDP model using the language that was described in Villela [15] during the knowledge capturing and classifying. Besides that, an ontology was developed to offer an additional dimension to classify the documents. Ontology is formal and explicit specification of a concept [16].

According to Gruber [16], SENAI Cimatec of BA focuses on codified knowledge (knowledge that was taken from its original container, the mind of individuals, and transferred to a written form) and uses centralized structure (functional attribution of Knowledge Management tasks and at least a department or group of people who are responsible for it, which supervise the operational organizational units to some degree), coordination by standardization (i.e. based on previous definition of knowledge processes and transfer of knowledge from an upper hierarchical position) and intrinsic motivation (i.e. a task is carried out by someone when it satisfies his/her immediate and own needs).

Considering the methodology that was proposed by Ferreira [21], a prototype of the process description component has been made available. It consists of a set of interlinked web pages, each one contains a diagram process and gives access to nested diagrams (web pages) that detail its processes or activities. It also offers a textual description of the activities in the lower level and it is capable of giving access to files holding explicit knowledge and to files containing output templates and examples.

As a result, the figure 1 shows the breakdown of the PDP. It is important to note that each sub-process can be carried out as part of the whole PDP or independently. This means, for example, a client can contract just the detailed design of a product since they have already elaborated the product concept or both the detailed design and the mold design. The availability of the product concept is indicated by the event "Client has the product concept", which is in short "Product Concept" in the diagram. The diagram that is illustrated in Figure 2 can be accessed from the diagram in Figure 1, clicking on the "Detailed Design" sub-process representation. Similarly a mouse click on the activity "Prepare Final Report" in Figure 2 gives access to the diagram that is shown in Figure 3 and clicking on the explicit knowledge that is referred to "IT35" gives access to the captured knowledge in the attached file, which is the work instruction for preparing the final report. (Phase 4 and Phase 5).

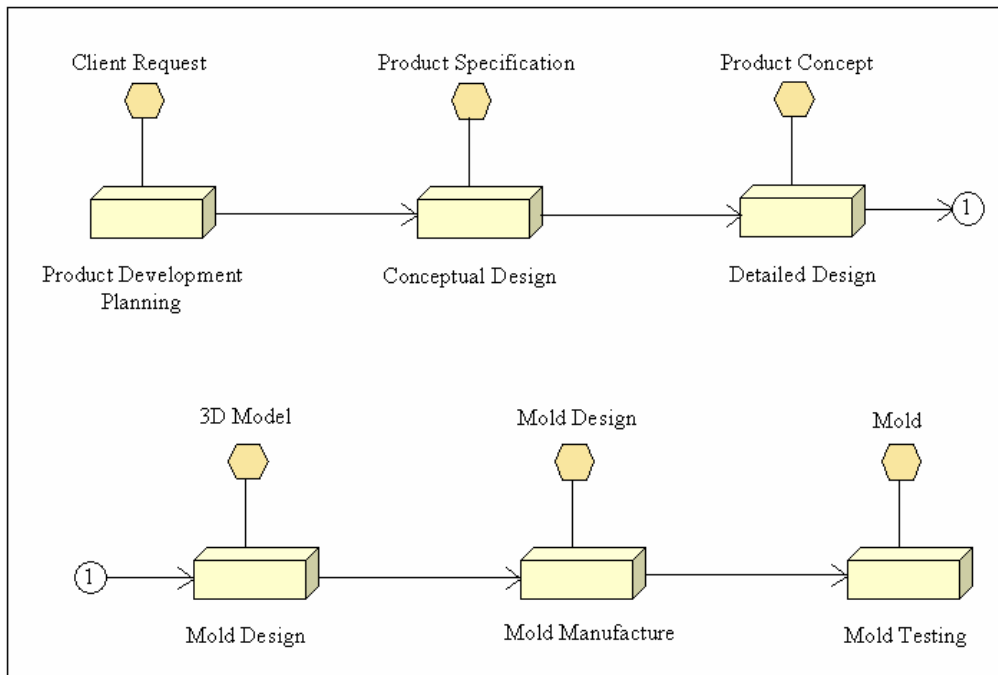

Figure 1. Breakdown of the product development process. [22]

Figure 2 gives a general idea of the detailed design sub-process, making the activities, their inter-relationships, inputs and outputs as well as the required explicit knowledge.

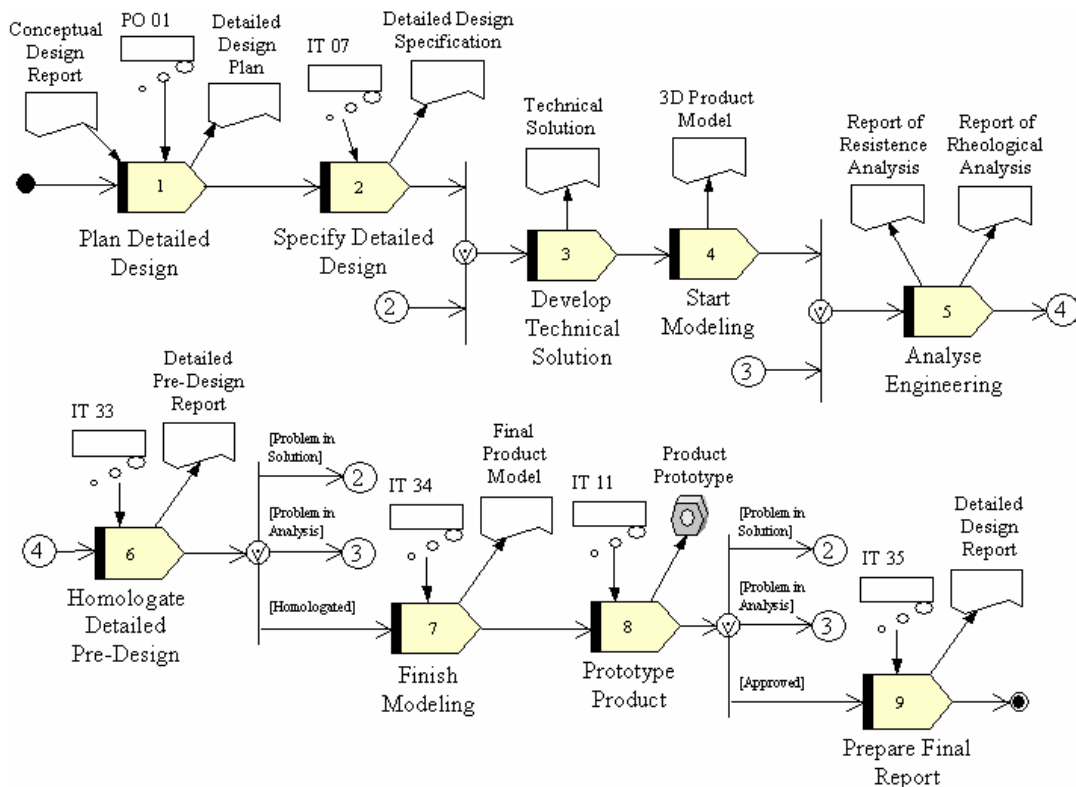

Figure 2. Breakdown of the detailed design sub-process.[22]

Figure 3 shows how the activity “Prepare Final Report” is carried out. To construct an ontology to Detailed Product Design Phase was adopted the process described in [11] based on the work developed by [16] and [21].

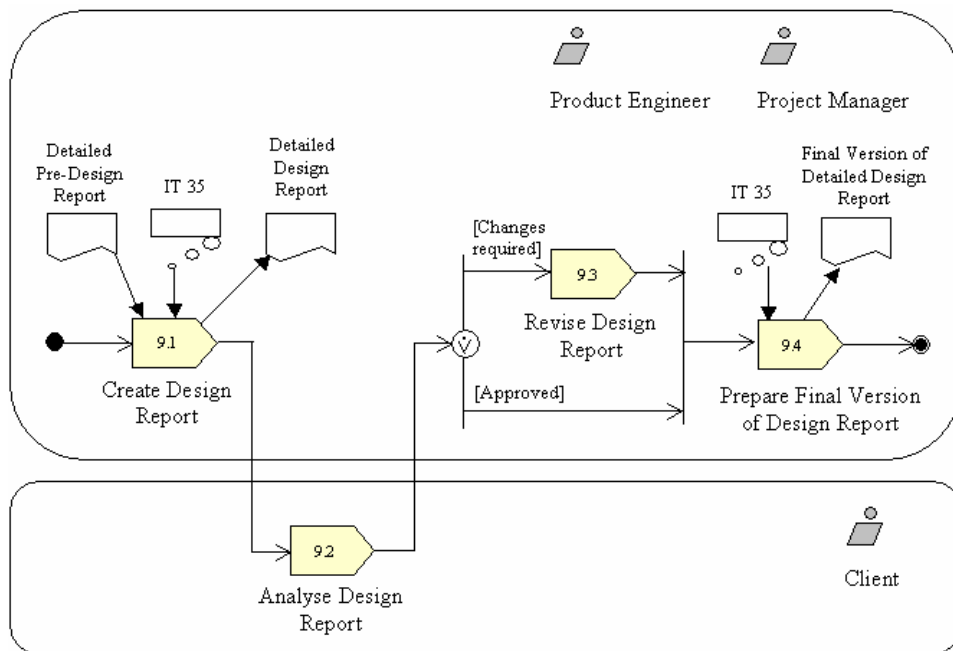

Figure 3. Activity of preparing final report. [22]

To construct ontology of the detailed product design phase (sub process) was considered the same approach that was adopted in [11] that was based on [16] and [21]. The figures 4 and 5 represent a part of the ontology developed.

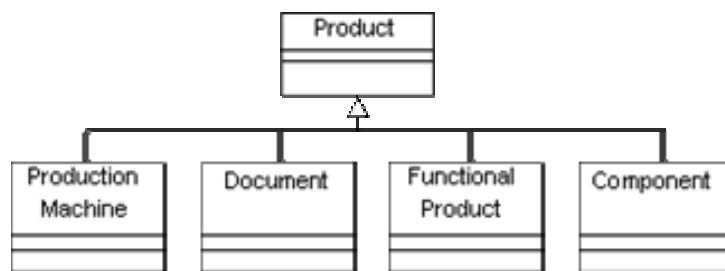

Figure 4. Detailed Design Phase Ontology

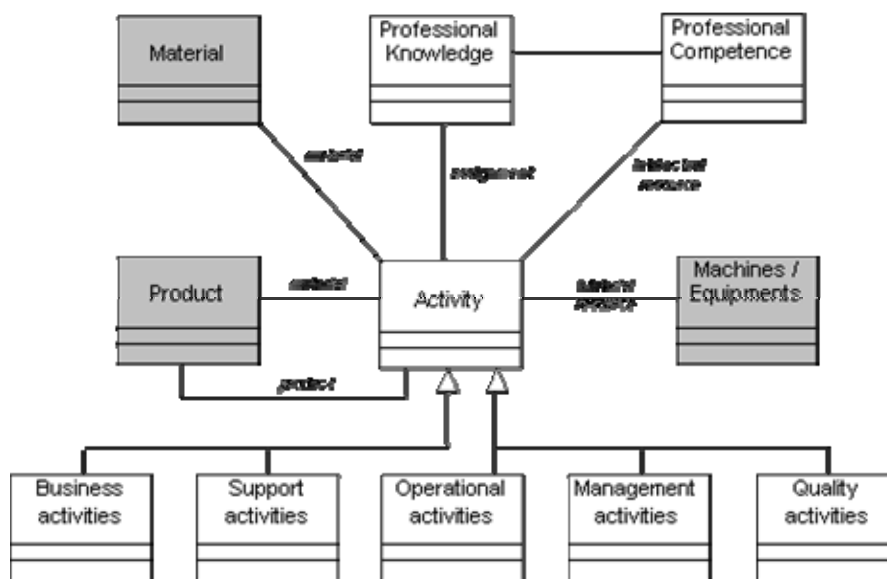

Figure 5. Details of ontology phase of the design product.[22]

7 METHODOLOGY VALIDATION

The design team was trained in the product development process and in the use of the system to use the developed system. The training process involved some classes to present the program's structure and potentiality. The designers and engineers received support from system's developers in the initial phase. It is important to stress that the design team has ISO 9000 culture and knowledge in design tools that facilitate the system implementation process.

The prototype was evaluated and validated using a questionnaire that was applied to 12 people who were involved in the product development process. The questionnaire was used as an instrument in the evaluation, containing 13 closed questions and 2 open questions. (Phase 6) The main comments about the prototype were:

- The model represents the PDP in a systematic and didactic purpose. It is easy to understand the design process. In case that a non-specialist person reads the model, it is possible to have a general vision of PDP. If this person would like to understand the model in details it is possible to explore sub-activities and access some specific information;
- It is possible to understand and to visualize the activities relationship, as well as the people and tools involved in activities;
- The model is able to access the documents that are necessary to develop the activities, as well as, the specialist who will develop each activities;
- The kind of knowledge is identified in the model;

On the other hand, some comments present opportunities to improve the model. These comments are:

- Some graphic elements were unfamiliar to the users, especially the logical operators;
- The model is static and some activities may not be carried out depending on the specific product.

Considering the questionnaire answer the model was improved and the questionnaire was applied again. Table 1 presents the result, which was obtained through analysis of closed answers. An evaluation was considered positive when the participant answered "Always" or "Almost always" to the questions such as "Could you understand the breakdown of the process activities?". Almost 50% of the participants answered "Sometimes" to the question related to the availability of the explicit knowledge. This was expected that only 40% of the operational patterns and 20% of the work instructions had previously been documented.

Table 1. Evaluation Result

Quantity of Questions	Percentage of Positive Evaluation
8	> 90%
2	> 80% and <= 90%
2	> 70%
1	> 50%

It is important to mention that the developed solution is an initial proposition and the consequence of the process can be improved.

8 CONCLUSIONS

This paper described a methodology to introduce Knowledge Management in companies having a focus in the product's development process. The described methodology is a general model and it can be applied in different business activities (manufacturing process).

The methodology application shows that the knowledge can be registered, accessed, shared and actualized by the users who are involved in business activities.

The model used to register the knowledge that is able to register different kind of information, satisfies the clients' needs (see the results of the questionnaire), considers the national and international standard (IT, PO, ISO 9000 and other) and supports the simultaneous engineering practices.

The main challenge in the Knowledge Management of the product management is to change the culture of the people. This challenge can be reflected in two process of KM, considering Nonaka and Takeuchi [7] classification. The first one is to turn tacit knowledge into explicit knowledge or socialization, which is a process of sharing experiences. Without sharing experience, it is difficult for anyone to know the process of other individual's reasoning. And, the second is to manage the tacit

knowledge to explicit knowledge or externalization, which there is an articulation of the individual's tacit knowledge in explicit concepts. These characteristic were observed in this work.

Managing the explicit knowledge to explicit knowledge or combination is basically a conversion process of some type of explicit knowledge that was generated by an individual to add up to the explicit knowledge of an organization. In this situation, a robust PLM (Product Life Cycle Management System) can support the KM.

The process models, which were obtained through the use of the new language take into account activities and their inter-relationships, actors, input artifacts and raw material, output artifacts, required and produced knowledge, as well as used goods as a resource for the execution of activities. These process models can provide the context in which certain knowledge is used, making it easier to understand, both the activity and the knowledge required to carry it out. As this process was developed in group, the fourth mechanism of KM was considered, and probably it was the main result of this work, the internalization of the knowledge. Internalization is the process of incorporating explicit knowledge of the organization into individual's tacit knowledge. This operational knowledge happens when design team reads/visualizes an individual study documents with different formats (i.e. texts, images, etc) and occurs individual interpretation and experimentation (learned lessons).

9 REFERENCES

- [1] Clark, K.B.; Fujimoto, T. *Product development performance: strategy, organization and management in the world auto industry*. Boston-Mass.: Harvard Business School Press, 1991.
- [2] Kemp, L.L., Nidiffer, K.E., Rose, L.C. et al. *Knowledge Management: Insights from the Trenches*. IEEE Software, 18, 6 (Nov/Dec. 2001), 66-68.
- [3] Drucker, Peter Ferdinand. *Administrando em tempos de grandes mudanças*. São Paulo: Pioneira, 1995.
- [4] Stewart, Thomas. *Capital intelectual: a nova vantagem competitiva das empresas*. Rio de Janeiro: Campus, 1998.
- [5] Gouvinhas, R.P and Costa, P.E.C. *The development of a Knowledge Management Model to Support Product Design Process with Brazilian SME Companies*. ICED. 2003.
- [6] Davenport, T.H., Prusak, L..*Conhecimento Empresarial: como as organizações gerenciam o seu capital intelectual*. Rio de Janeiro: Campus, 1998.
- [7] Nonaka, I.; Takeuchi, H. *Criação de conhecimento na empresa*. Rio de Janeiro, Campus, 1997.
- [8] Rubenstein-Montano, B., Liebowitz, J., Buchwalter, J. et al. *A Systems Thinking Framework for Knowledge Management*. *Decision Support Systems*, 31, 1 (May 2001), 5-16.
- [9] Skyrme, D. *Knowledge Management Solutions - The IT Contribution*. SIGGROUP Bulletin, 19, 1 (1998), 34-39.
- [10] O'Leary, D. *How Knowledge Reuse Informs Effective System Design and Implementation*. IEEE Intelligent Systems, 16, 1 (2001), 44-49.
- [11] Jablonski, S., Horn, S. and Schlundt, M. *Process Oriented Knowledge Management*. In: Proceedings of the 11th International Workshop on Research Issues in Data Engineering (Heidelberg, Germany, Apr, 2001), 77-84.
- [12] Maier, R. and Remus, U. *Towards a Framework for Knowledge Management Strategies: Process Orientation as Strategic Starting Point*. In: Proceedings of the 34th Hawaii International Conference on System Sciences (Maui, Hawaii, Jan, 2001), 4023.
- [13] Oh, E. and Hoek, A. *Adapting Game Technology to Support Individual and Organizational Learning*. In: Proceedings of 13th International Conference on Software Engineering & Knowledge Engineering (Buenos Aires, Argentina, Jun, 2001), 347-362.
- [14] Holz, H., Könnecker, A. and Maurer, F. *Task-Specific Knowledge Management in a Process-Centred SEE*. In: Lecture Notes in Computer Science: Advances in Learning Software Organizations, 2176, Springer, 2001, 163-177.
- [15] Villela, K. *Definição e construção de ambientes de desenvolvimento de software orientados a organização*. 2004. Dissertação (Doutorado). UFRJ, 2004.
- [16] Gruber, T.R. *Ontolingua: A mechanism to support portable ontologies*, version 3.0. Technical Report, Knowledge Systems Laboratory, Stanford University, 1992.
- [17] Cruz, T. *Workflow – A Tecnologia que vai revolucionar processos*. São Paulo: Atlas, 1998

- [18] Smith, R.P. and Morrow, J.A. *Product development process modeling*. Design Studies Vol 20 No 3 May.1999.
- [19] Ferreira, C.V. *Metodologia para as Fases de Projeto Informacional e Conceitual de Componentes de Plásticos Injetados Integrando os Processos de Projeto e Estimativa de Custos*. Programa de Pós-Graduação em Engenharia Mecânica. UFSC. Tese (Doutorado). 2003.
- [20] Trittman, R. *The Organic and the Mechanistic Form of Managing Knowledge in Software Development*. In: Lecture Notes in Computer Science: Advances in Learning Software Organizations, 2176, Springer, 2001, 22-36.
- [21] Falbo, R. *Integração de Conhecimento em um Ambiente de Desenvolvimento de Software*. 1998. Tese (Doutorado). COPPE/UFRJ, Rio de Janeiro, 1998.
- [22] Tamanini, M.T. *Uma proposta para Gerência do Conhecimento ao longo do Processo de Desenvolvimento de Produto*. Programa de Pós-Graduação. Mestrado em Redes de Computadores. Tese (Mestrado). Unifacs, Salvador, 2005.

Contact: Cristiano Vasconcellos Ferreira
Institution: SENAI BA Cimatec – Integrated Technology and Manufacturing Center
Address: Avenida Orlando Gomes, 1845 – Piatã
41650-010 – Salvador – BA- Brasil
Phone:+ (55) (71) 3462-8437
Fax: + (55) (71) 3462-9599
e-mail: cristiano@cimatec.fieb.org.br / cristianoverreira@bol.com.br
<http://www.fieb.org.br>

Contact: Maria Teresinha Tamanini Andrade
Institution: CEFET BA – Centro Federal de Educação Tecnológica da Bahia
Address: Rua Emídio dos Santos, s/n – Barbalho
403150-010 – Salvador - BA
Country: Brasil
Phone:+ (55) (71) 2102-9400
e-mail: tamanini@cefetba.br / leotere@uol.com.br
<http://www.cefetba.br>

Contact: Karina Barreto Villela
Institution: UNIFACS - Universidade Salvador
Address: Rua Ponciano Oliveira, 126 – Rio Vermelho
41950-275 – Salvador - BA
Country: Brasil
Phone:+ (55) (71) 3330-4630
e-mail: karina.villela@gmail.com